



LGate 120

RESIDENTIAL SOLAR MONITORING SOLUTION

The LGate 120 is a single-phase electronic watt-hour meter for remote monitoring of solar photovoltaic systems. It features a smart communications module to automatically transmit meter data over cellular or Ethernet networks allowing system owners and operators to easily manage distributed solar assets.

The LGate 120 combines a revenue-grade, solid-state power meter with an advanced communications gateway. These components work in conjunction to remotely monitor the performance of residential solar energy installation regardless of panel or inverter type. The LGate 120 is a one-piece completely under glass meter which installs easily using a standard socket base. Performance data is uploaded in near real-time to the Locus Energy SolarOS monitoring platform which provides a suite of tools and analytics for asset managers.

DATA COLLECTION

AC energy data is collected by the meter and passed to the communications module. Additional system performance data can be collected directly from meteorological sensors and supported inverters via available RS-485 or Zigbee connections. All data is stored in non-volatile memory and then automatically uploaded to the SolarOS and SolarNOC platforms.

NETWORK CONNECTIVITY

The communications gateway inside the LGate 120 supports plug and play connectivity through a cellular or available Ethernet network connection. Once the unit is installed and powered on, it will immediately begin transmitting data without any configuration. For maximum reliability, the communications gateway will automatically route uploads between the wireless and wired connections if either of the networks are unavailable.

KEY FEATURES:

- ANSI C 12.20 power meter
- RS-485 and Zigbee inputs
- GSM cellular or Ethernet connectivity
- Over the air firmware updates
- Easy, low cost installation
- Doesn't require entrance into the building
- Plug and play activation
- LCD display



DIAGRAM – TYPICAL CONFIGURATION

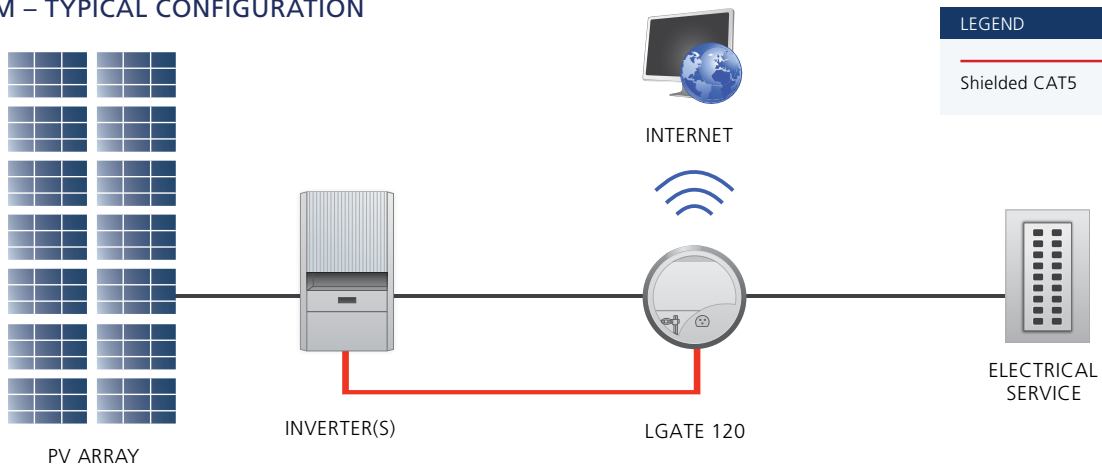

DIMENSIONS

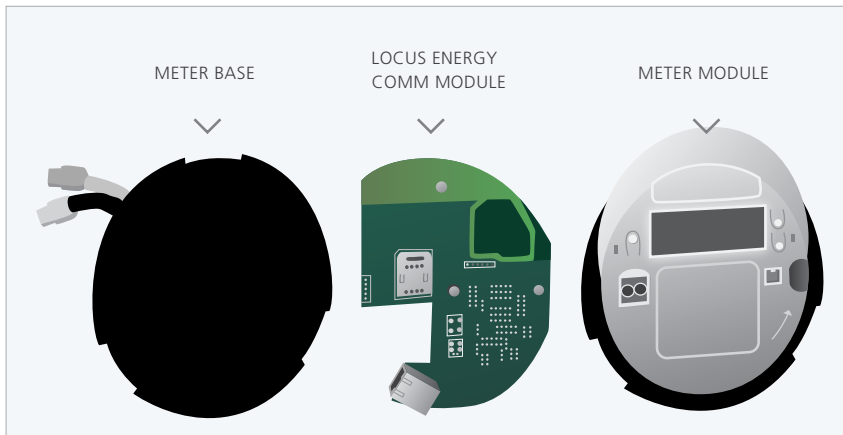

SOCKET METER

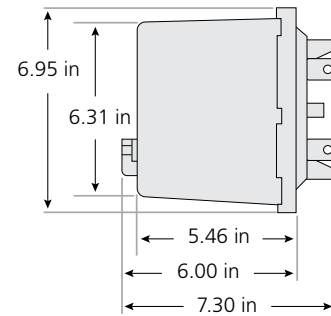

SPECIFICATIONS

DATALOGGER	
Processor	ARM9 embedded CPU
OS	Custom version of Linux 2.6, OTA firmware updates
Memory	128 MB RAM
Display	LCD screen

PHYSICAL	
Enclosure	NEMA 3R Type
Weight	8 oz
Dimensions	6.95" x 6.5" x 7.3"
Environment	-20 to 60C, all-weather
Warranty	5 year limited warranty

COMMUNICATION INTERFACE OPTIONS			
Model Number	LGate120-3Gx	LGate120-3Gy	LGate120-3Gz
Cellular - 3G GSM	✓	✓	✓
RS-485 2 and 4 wire		✓	
Modbus		✓	
Zigbee			✓
Ethernet RJ-45 10/100, DHCP/Static		✓	

POWER	
Accuracy	ANSI 12.20 (Class
Voltage Inputs	0.2%) 120 - 480 VAC
Max. Current Input	200 A
Service Type	Single phase , 60 Hz 2S
Socket Type	

COMPLIANCE	
ANSI 12.20 class 0.2%	
FCC Part 15B	
PTCRB	
AT&T Carrier	
Compliance	